



**Strand Pelletizer SGS 300-E4**



**C · F · SCHEER & CIE GmbH + Co. KG**

---

# Strand Pelletizer SGS 300-E4

The one-sided bearing on the SGS 300-E4 makes the machine ideally accessible for efficient cleaning. The cutting housing can be easily unlocked and opened for complete accessibility to the cutting rotor and feed rolls. The cutter assembly is now completely open so that it can be easily cleaned. As a result, the downtimes associated with each change of material, have been significantly reduced compared with rotors of the same cutting width running in bearings on both sides.

The optimized cutting geometry of the new pelletizer guarantees excellent cutting results. The new SGS 300-E4 is the ideal machine when materials are frequently changed.

## Advantages of the Strand Pelletizer SGS 300-E4

- ◆ 300 mm cutting width for high throughputs
- ◆ easy elevation of strand infeed chute and feed roll with only two steps
- ◆ cutter assembly can be easily cleaned due to complete and free accessibility
- ◆ suitable for the entire product range: from very soft to very brittle, natural to highly filled and highly reinforced
- ◆ because of the minimum downtimes, this is the ideal machine when materials are frequently changed ( approx. 3 min for a complete cleaning)



## Technical Data

Strand Pelletizer		SGS 300-E4
Cutting width	mm	300
Max. no. of strands	Ø 3 mm	60
Strand speed <sup>1</sup>	m/min	20-80
Power	kW	15
Drive		frequency converter
Max. throughput	kg/h	2000/1500 glass fibre reinforced

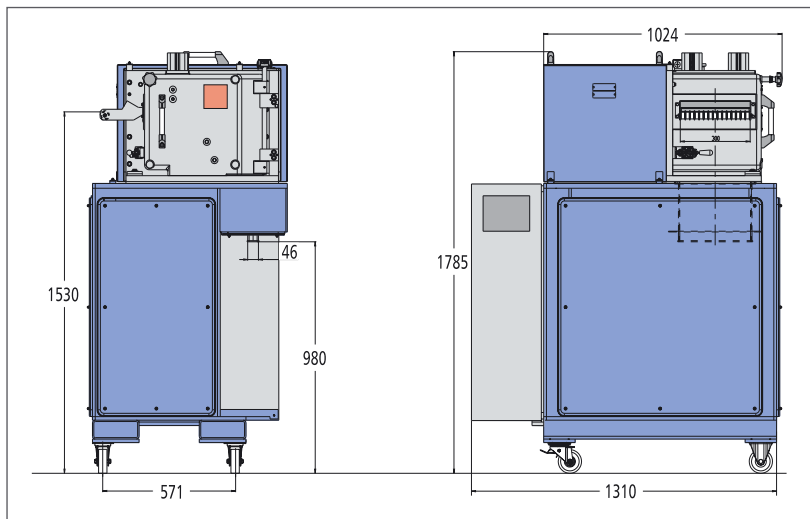

Complete and free accessibility by unilateral support of the pelletizing unit.



The upper feed roll and the strand infeed chute are simply elevated to enable much faster cleaning.

<sup>1</sup> Different strand speed upon request  
(Technical data can vary depending on the process)  
Subject to change without notice